

DRAUSICHT - ohne , GPD, SMA3
TOP VIEW - without , GPD, SMA3

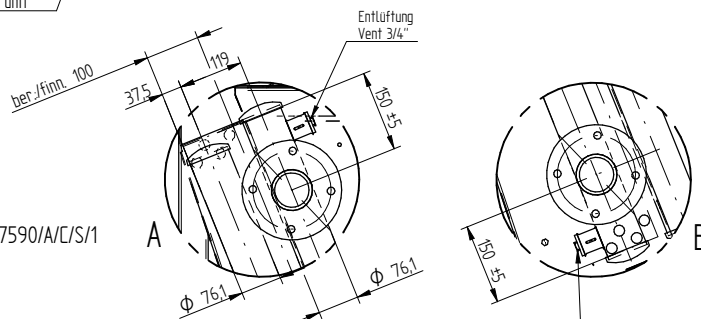

Schwingmetall-Dämpfelement (lose)
Vibration damper (loose delivered)
SMA3, GN 09.04.01; 500-700kg

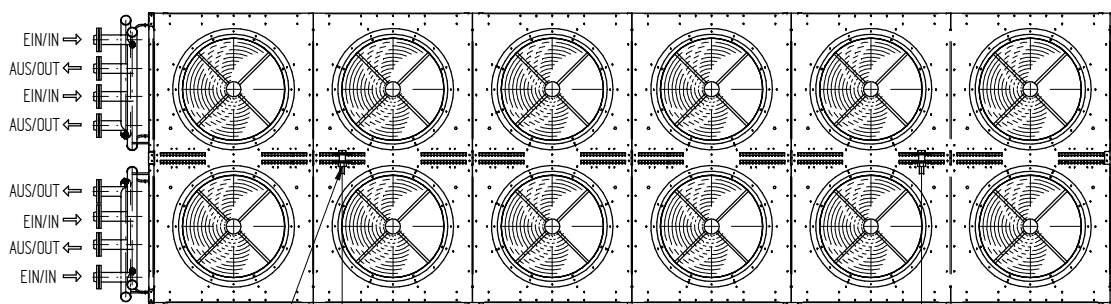
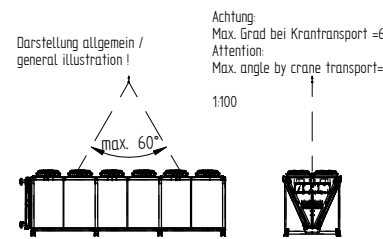
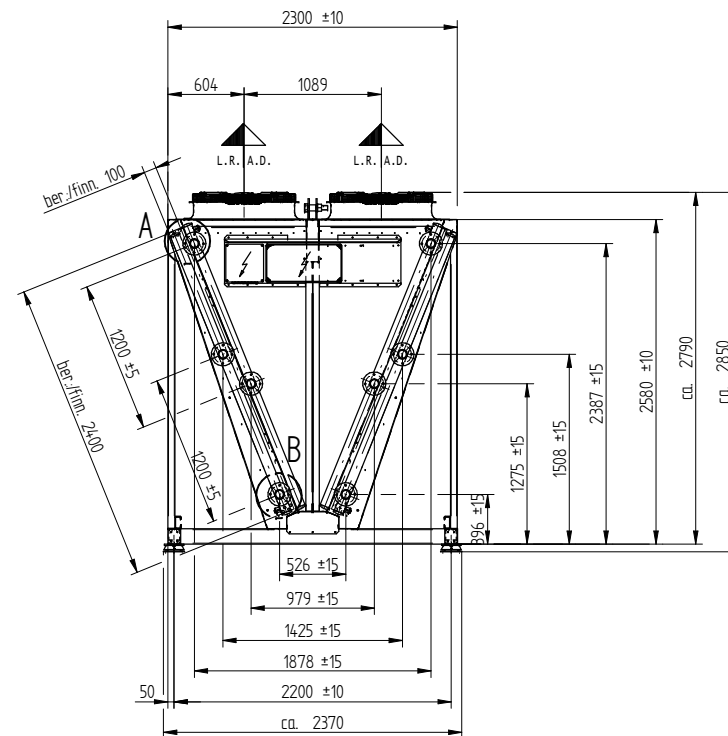
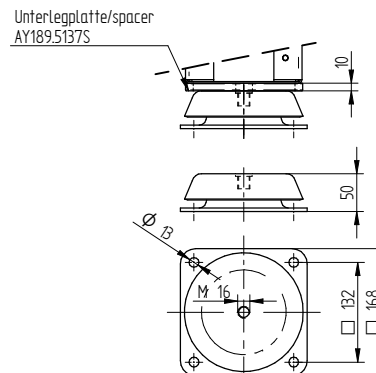

Technische Daten / technical data.

Blocktyp / type of coil: 2 x F/04/048/2,40/07590/A/C/S/1
Kernrohre / tubes: Cu ø 12 mm
Lamellen / fins: AL
Lamellenteilung/fin pitch: 240 mm
Rohrteilung / tube pitch: 50 x 25 mm
Gehäuse / housing: St. verz. / st. sed., Lackiert / painted RAL7035 lichtgrau / light grey

Kreislauf No of circuit	Paßzahl No of passes	Stränge No of distr.	Verteilrohr Cu header inlet		Sammelrohr Cu header outlet		Rohrvolumen vol. of tubes l	Austauschfl. exch. surface m ²	Leergewicht weight empty kg	Betriebsgewicht working weight kg	Entleerung Drain 3/4"
			ø	Ein Cu ø Tube in	ø	Aus Cu ø Tube out					
1	2	96	76,1	2x DN65/PN10	76,1	2x DN65/PN10	186,5	1422,6	ca. 3430	ca. 3800	
2	2	96	76,1	2x DN65/PN10	76,1	2x DN65/PN10	186,5	1422,6			

Axialventilatordaten / axial fan data. (VT03060U.1) ID: 2670

ø mm	Ventilator typ / fan type	l / min	kW eL	A	V	Ph	Hz	Anz./pcs
800	S3G800-EG95-09	770	0,9	15	400	3	50-60	12

Sonderkonstruktion/Spec. construction:

- EC-Ventilatoren ohne Motormanagement
- 8 x Schwingmetallfüße SMA3
- Komplettmontage mit Verdrahtung am Gerät
- 8 x Flanschpaare DN65/76/PN10 LosFL ; DIN EN 1092-1
- Anschluss auf Klemmkasten mit 0-10 V
- GPD-EC- Sicherungskasten
1x 5209010 Gehäuse 900 x 300 x 132 mm
- EC-fans without motor management
- 8 x vibration dampers SMA3
- completely mounted and wired
- 8 x pair of flanges DN65/76/PN10 " DIN EN 1092-1
- Connection to junction box 0-10 V
- GPD-EC- fuse box
1x 5209010 housing 900 x 300 x 132 mm

revision	date	name	drawing number	index
02.03.2017	kgortva	customer	400-0000640876	
03.03.2017	sgergely	project/ quantity	101045353	1
		order/ position	FV1047872	130



Güntner GmbH & Co. KG
Hans-Güntner-Strasse 2-6
82256 Fürstenlebrück
GERMANY
Tel: +49 8141 242-0
Fax: +49 8141 242-155