

REP	QTE	DESIGNATION	DESCRIPTION	MATIERE	REFERENCE	REFERENCE DE COMPOSANT
38	2	PIQUAGE BRIDE PLATE ACIER PN10-16	DN80_PN10-16_L160	S235JR	P80P16L16A	
37	6	PIQUAGE BRIDE PLATE ACIER PN10-16	DN100_PN10-16_L160	S235JR	P100P16L16A	
36	5	SUPPORT TUYAUTERIE-21001336-04	EP5	S235JR		
35.5	1	CLAPET CASSE VIDE	DN80	Laiton/316Ti	CCV80	
35.4	1	DEGAZEUR GRAND DEBIT	Defaut	INOX	PURGGD	
35.3	2	SOUPAPE DN32 4BARS	Defaut	-	70010165023	
35.2	1	THERMOMETRE CHAUD AXIAL INOX D80	D80 0 à 120°C L200	-	70010230008	
35.1	10	ETRIER FIXATION	SUP. OU = 80 000L	ACIER PEINT	10060010015	
35	1	ACCESSOIRES-21001336-04	Defaut	-	-	
34	1	JAQUETTE_TOLE_ISOXAL_ONDULEE-21001336-04	100000L	3005-H25	10000500001	
33	4	REHAUSSE PIED DE TRANSPORT H=110 mm	Defaut<Brut d'usinage>	S235JR	GF-0052	
32	1	PIED DOUBLE	Ø3000	S235JR	PITRH300A	
31	2	RENFORT CIRCULAIRE ANNEAU ACIER 120X280X5	Ø3000	S235JR	10060000088	
30	2	ANNEAU MANUTENTION	AMT3000	S235JR	AMT3000A	
29	4	PIQUAGE BRIDE PLATE ACIER PN10-16	DN80_PN10-16_L160	S235JR	P80P16L16A	
28	2	PIQUAGE FILETE	DN32_L150	S235JR	20080000009	SOUPAPE
27	1	MANCHON ACIER_TARAUDE	DN15 - L135	S235JR	20030000026	THERMOMETRE
26	4	MANCHON ACIER_TARAUDE	DN15 - L135	S235JR	20030000026	
25	2	RENFORT TH ACIER	500-Ø3000-LARG120-EP6	S235JR	RFTH500300A	
24	2	KIT VISSERIE	TH500 M16 CL8.8	Zingué	KAV50024M16	
23	2	COUVERCLE TH ACIER	TH500-EP20	S235JR	PLTH500A20	
22	2	JOINT TH	500	BURASIL BASIC 9544-B	80010003001	
21	2	TROU D'HOMME PENETRANT ACIER	TH500 L160 7-10Bars	S235JR	TH50PA16	
20	1	KIT VISSERIE	TH400 M14 CL10.9	Zingué	KAV40016M14	
19.3	1	PIQUAGE BRIDE PLATE	DN80_PN10-16_L160	S235JR	P80P16L16A	CLAPET CASSE VIDE
19.2	1	MANCHON TARAUDE ACIER	DN15 - L135	S235JR	20030000026	DEGAZEUR
19.1	1	COUVERCLE TH ACIER	400	S235JR	10030030005	
19	1	COUVERCLE TETE ACIER GC	TH400 DN80-DN15-CALO100	-	CPTH8015A	
18	1	JOINT TH	400	BURASIL BASIC 9544-B	80010003042	
17	2	PAIRE OREILLE DE MANUTENTION SUP 50 000L	OMT3000A	-	OMT3000A	
16.3	8	GOUSSET TETE ACIER	80x100	S235JR	GT80X100A	
16.2	1	TROU D'HOMME PENETRANT ACIER	TH400 L170 FB	S235JR	TH40PA17	
16.1	1	FOND BOMBE ACIER	GRC-3000_PE Ø25	S275JR	10050020002	
16	1	TETE BALLON ACIER GC-	Ø3000 TROU D'HOMME 400 L170	-	T300TH40L17A	
15.10	1	PIED INFÉRIEUR	Ø3000	S235JR	PITRB300A	
15.9	1	ANNEAU MANUTENTION	AMJ3000	S235JR	AMJ3000A	
15.8	1	CERCLAGE FIXATION JAQUETTE	Ø3000 - CALO100	S235JR	10020000000	
15.7	1	ANNEAU CANNE	AMC3000A	S235JR	AMC3000A	
15.6	1	CANNE VIDANGE_INOX	FILETE DN80-Ø3000	316L	CV3000DN80X	
15.5	10	GOUSSET JUPE	GJ3000A	S235JR	GJ3000A	
15.4	1	FER U60	3000	S235JR	10020060002	
15.3	1	JUPE-ACIER-STD-2	3008-CANNE DN80	S235JR	10000001022	
15.2	1	JUPE-ACIER-STD-1	3008-CANNE DN80	S235JR	10000001022	
15.1	1	FOND BOMBE ACIER	GRC-3000_PE Ø25	S275JR	10050020002	
15	1	JUPE-ACIER-ECS	3008-CANNE DN80	-	J3008DN80AX	
14	1	VIROLE BALLON ACIER Ø3000 SOYEE-2C1-2-21001336-04	Ø3000-1960	S235JR	10000001038	
13	1	VIROLE BALLON ACIER Ø3000 SOYEE-2C1-1-21001336-04	Ø3000-1960	S235JR	10000001038	
12	1	VIROLE BALLON_SOYE-1C6-2-21001336-04	100000L	S235JR	10000001038	
11	1	VIROLE BALLON_SOYE-1C6-1-21001336-04	100000L	S235JR	10000001038	
10	1	VIROLE BALLON_SOYE-1C5-2-21001336-04	100000L	S235JR	10000001038	
9	1	VIROLE BALLON_SOYE-1C5-1-21001336-04	100000L	S235JR	10000001038	
8	1	VIROLE BALLON_SOYE-1C4-2-21001336-04	100000L	S235JR	10000001038	
7	1	VIROLE BALLON_SOYE-1C4-1-21001336-04	100000L	S235JR	10000001038	
6	1	VIROLE BALLON_SOYE-1C3-2-21001336-04	100000L	S235JR	10000001038	
5	1	VIROLE BALLON_SOYE-1C3-1-21001336-04	100000L	S235JR	10000001038	
4	1	VIROLE BALLON_SOYE-1C2-2-21001336-04	100000L	S235JR	10000001038	
3	1	VIROLE BALLON_SOYE-1C2-1-21001336-04	100000L	S235JR	10000001038	
2	1	VIROLE BALLON_SOYE-1C1-2-21001336-04	100000L	S235JR	10000001038	
1	1	VIROLE BALLON_SOYE-1C1-1-21001336-04	100000L	S235JR	10000001038	

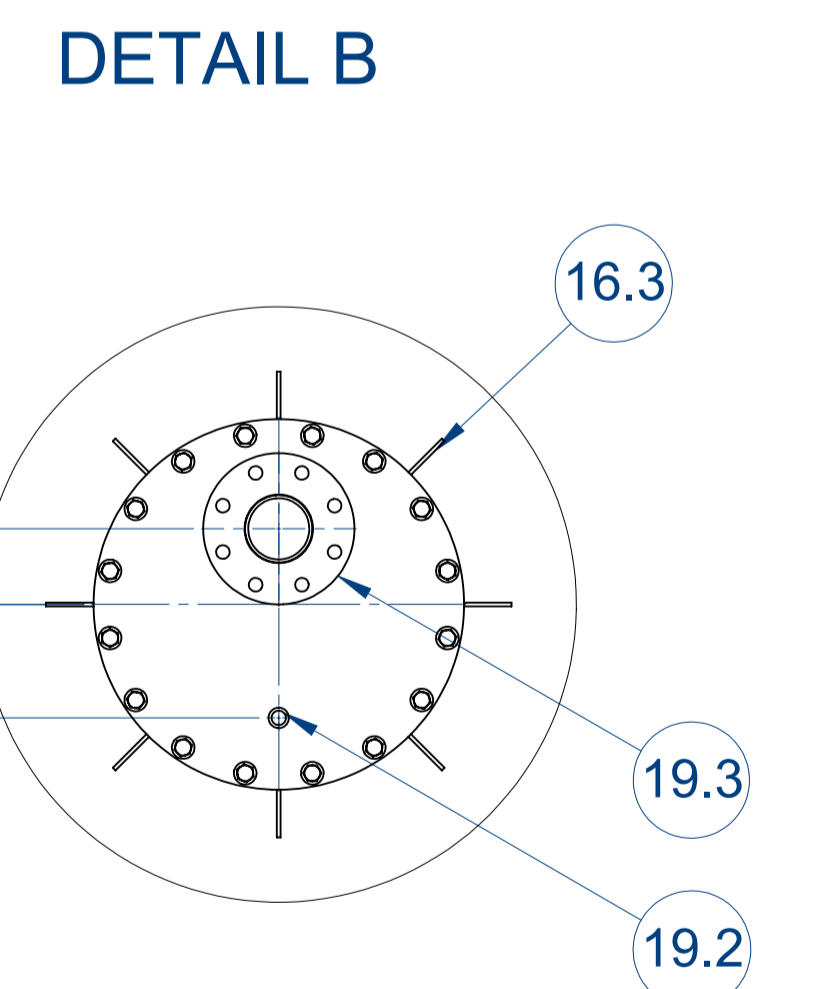
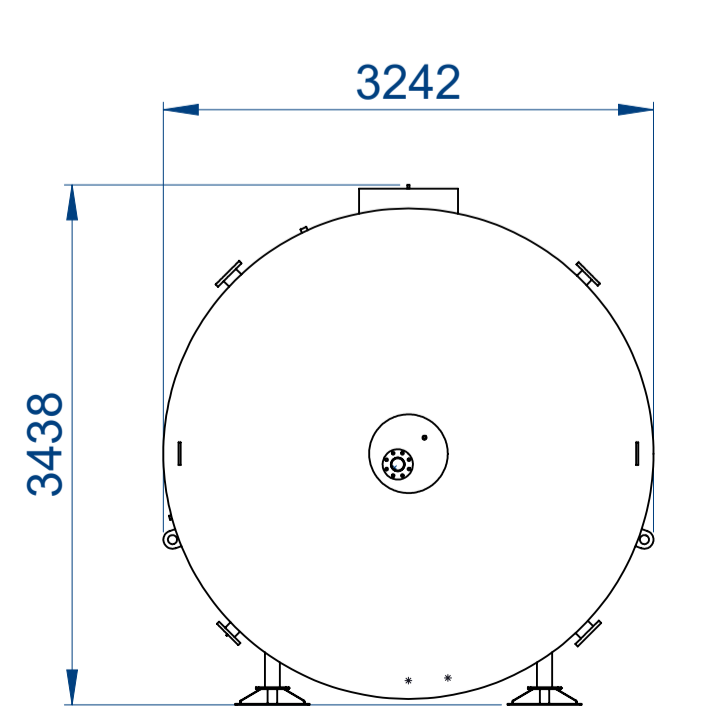
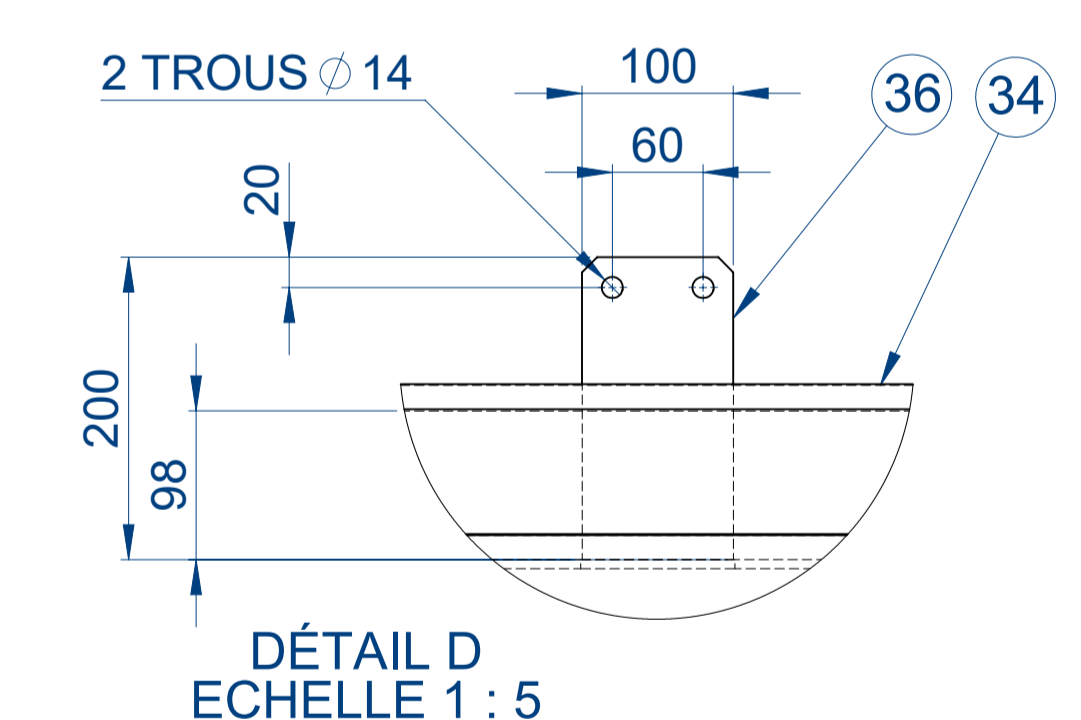
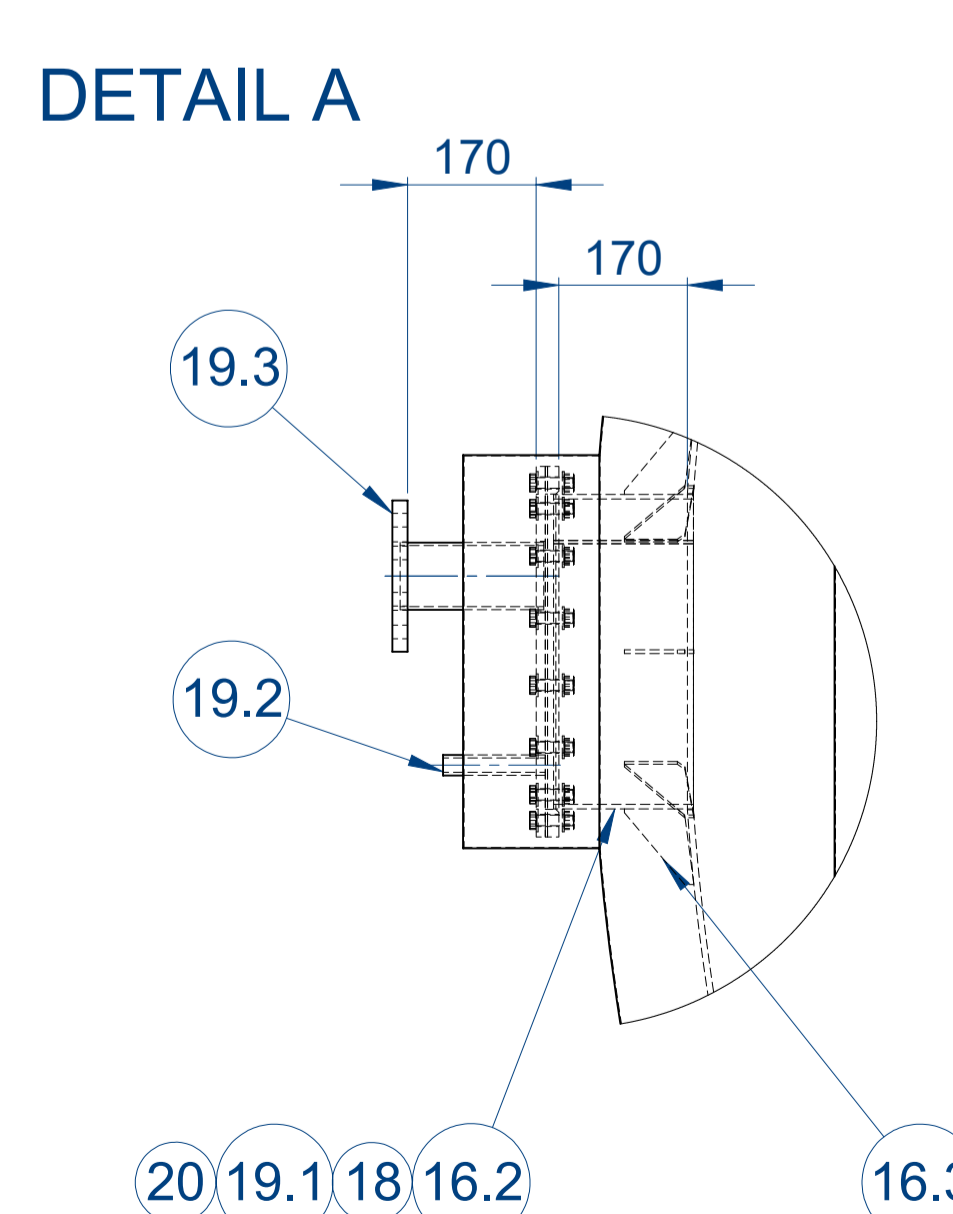

IND.	DATE	DESIGNATION	NOM
SAUF INDICATION CONTRAIRE: LES COTES SONT EN MILLIMÈTRES		CUIVE : Ø 3000 ACIER S235JR EP 6	PLAN APPROUVE
ÉTAT DE SURFACE:		FONDS : GRC DROIT ACIER S275JR EP 8	PLAN A MODIFIER
TOLÉRANCES:		REVÊTEMENT INTÉRIEUR : TYPE ACS	Le: _____
LINÉAIRES : js18 - JS18		CALORIFUGÉAGE : MO	Signature: _____
ANGULAIRES : ± 3°		ÉPAISSEUR : 100 LAINE MINÉRALE	
SPECIFICATIONS		JAQUETTE : TOLE ISOXAL FIXE ONDULEE	
		CALORIFUGÉAGE DU FOND INFÉRIEUR	
		PS MAXI : 4 BARS	
<b>Lacaze Energies</b> LES CANARDES D'AUZEAN 32440 CASTELNAU D'AUZEAN B.P. 2 46 220 LEYME Tel: (33)05 69 40 36 39 Fax: (33)05 69 40 38 40 SIRET: 500 911 601 00017		NOM: Fouzanet Benoit Date: 01/10/21 CENTRE DE GRAVITE: X: -6502.44 Y: -0.65 Z: 3.05 MASSE: 9321.74 Kg MATIERE: ACIER S235JR Qte: 1 Ech: 1:25 Pl: 1/2 A1	REF: 21001336-04 N°: 21001336-04-C BALLON TAMPON EAU CHAUDE SANITAIRE - 100 000L - VERTICAL EXTERIEUR